

GMC SAVANA

BACK DOOR



ENSURE THAT THE VEHICLE E.O. DOOR LATCH IS FUNCTIONING CORRECTLY. READ THE SUPPLIED INSTALLATION INSTRUCTIONS FULLY BEFORE STARTING ANY FITTING OF THIS LOCK

- 1-Remove any ply-lining (if fitted), from both lower rear door sections.
- 2- Remove both lower rear panels using a suitable trim clip tool.
- 3-Clean area where lock will be fitted.
- 4-Stick adhesive drilling template to door in line with measurements market below.



Photo 1

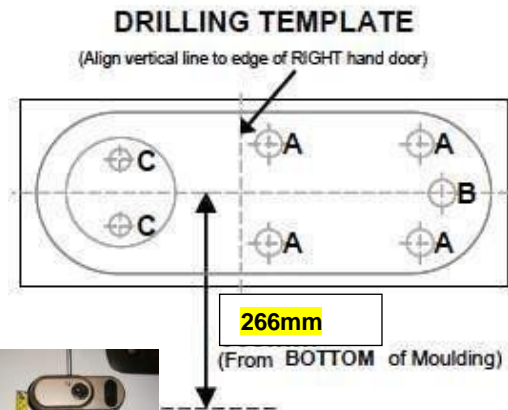

2018/01/24

Drilling Fixing Holes

- Centre punch, drill pilot holes (A, B & C)
- Remove template.

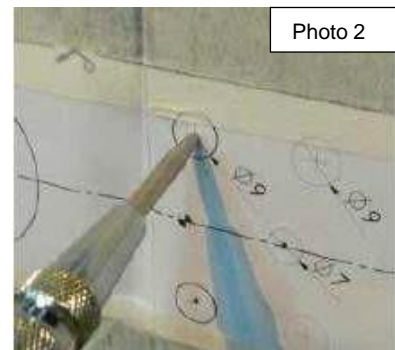
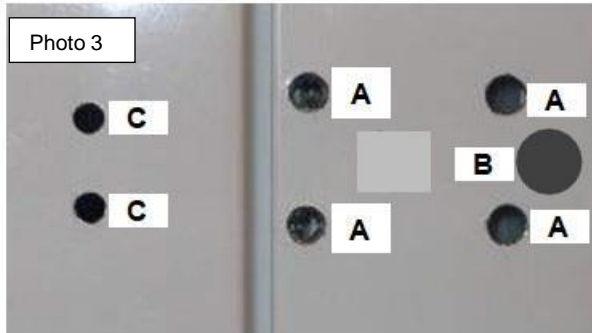

Photo 2

## FITTING INSTRUCTIONS

### BACK DOOR



- Drill 4 x holes **(A)** to a maximum size of **9mm**.
- Drill 1 x hole **(B)** to a maximum size of **10mm**.
- Drill 2 x holes **(C)** to a maximum size of **9mm**.  
**Note: it will also be necessary to drill through the edge of an inner brace, when drilling holes (C).**

(Note: All holes should be de-burred, where possible).

- Apply the anti-corrosion substance supplied, or paint holes.

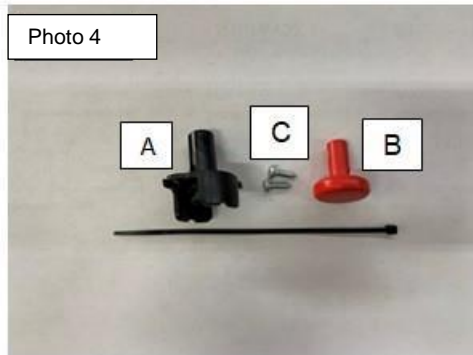

### Escape Cable Handle Components

Remove the following:-

- A.** Cable Collar Support Bracket.
- B.** Escape Knob.
- C.** Small fitting screws.

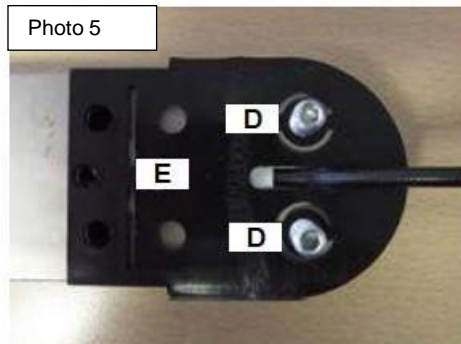

### Assemble Unit prior to fitting to door

Fit 2 x **M8 Studs** with plusnuts **(D)** (fit with socket heads facing inwards). (Use of a thread locking compound is recommended). Fit Plastic Lock Shroud **(E)** over Escape Cable and Studs

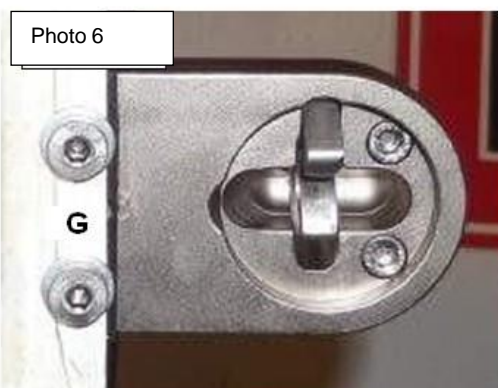

### Fitting Gatelock Van to door

- Insert **Escape Cable** through hole **(B)**, followed by **M8 studs**.
- Hold unit, fit **M8 Cap Bolts** with **Lip Plate** through door edge **(G)**. **(DO NOT TIGHTEN FULLY)**.

**FITTING INSTRUCTIONS**

**BACK DOOR**

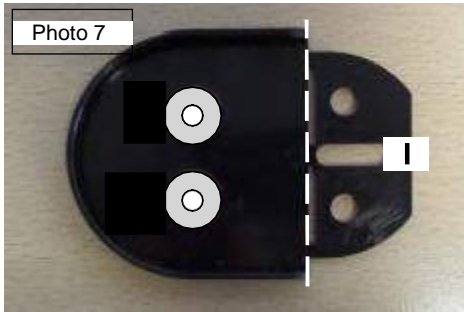

- Remove Plastic 'Unit Tilt' section (I).

Use cut off section (I) if Unit requires tilting over to improve locking, (this is more typical for barn doors).



- **Cut the edges where they will be installed the plusnuts.**

Fitting Locking Strike

- Apply an anticorrosion substance or paint holes
- Fit M6 screws through strike plate with plusnuts
- Fit screws through plastic shroud.
- Fit screws through drilled holes



Internal Escape Cable Fitting

**Step 1:** Drill a 13mm hole on the door sheet metal (Or panel)

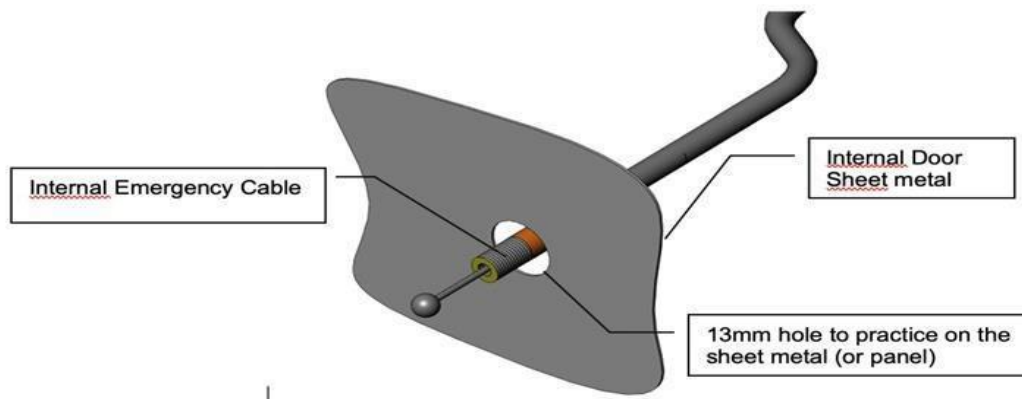

## FITTING INSTRUCTIONS

## BACK DOOR

**Step 2:** Insert the red knob in its support, paying attention to align the holes as indicated below

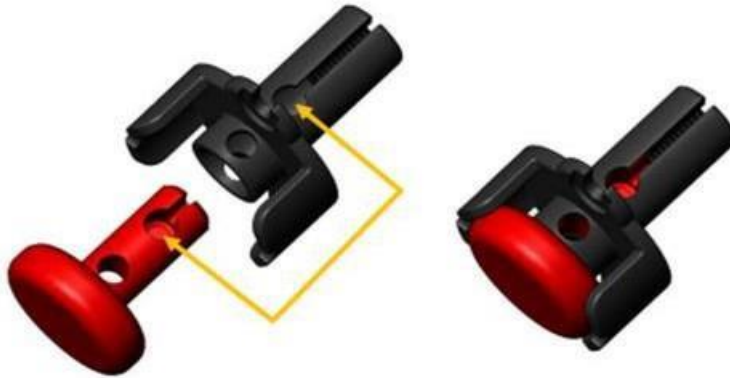

**Step 3:** Insert the terminal of the cable in its seat.

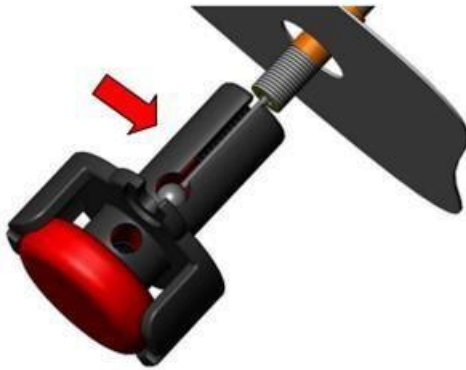

**Step 4:** Screw the plastic support until the ball end of the cable aligns with the top hole of the support



**Step 5:** Insert the support into the door sheet metal and close the padlock by rotating the harpoon (the red knob will return). Carry out some functional tests before fixing the plastic support. If necessary, screw or unscrew the support to adjust the stroke.

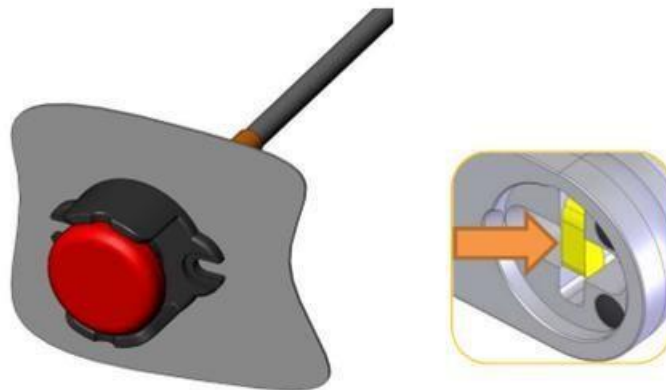

## FITTING INSTRUCTIONS

## BACK DOOR

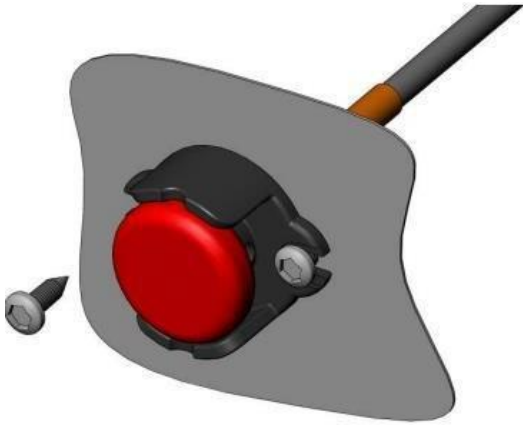

**Step 6:** Fix the support to the door sheet onto the panel using the screws provided. Check that the passing hole of the knob and that of the support are aligned in order to guarantee the passage of the safety seal.

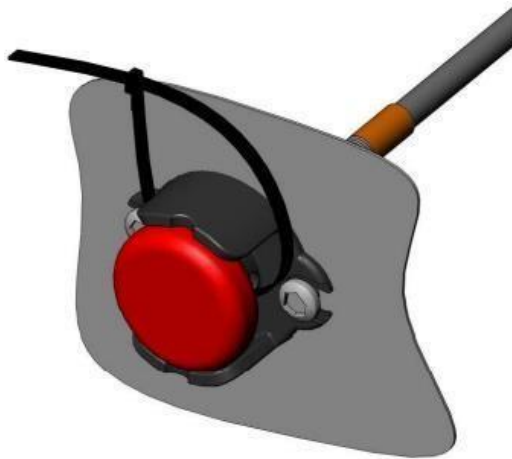

**Step 7:** Fix the support to the door sheet or to the panel using the screws provided.

**NOTE:** The emergency cable allows the use of a security seal. The use is **NOT MANDATORY** and it prevents the functioning of the emergency cable in case of any need.

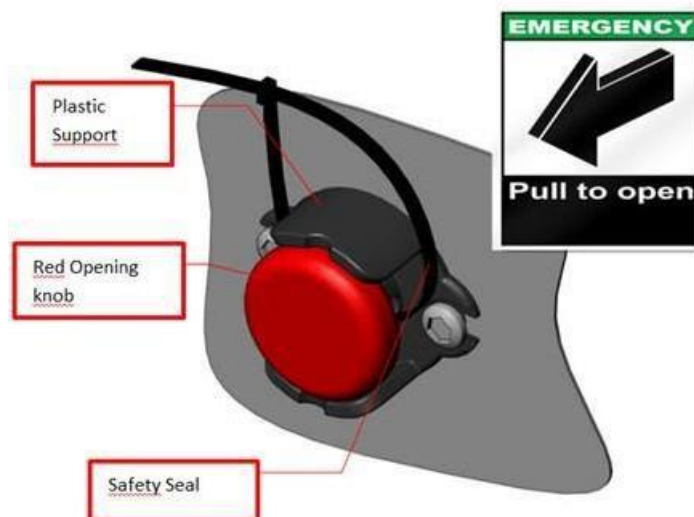

## FITTING INSTRUCTIONS

## BACK DOOR

Hold Emergency Escape Cable

- Choose a position on the inside face of the door That has adequate access to fit the cable through The door (ensure cable will not be kinded or Interfere with latch etc)
- Centre punch, drill 8mm hole
- Push plastic support through drilled hole, fit screws to secure.

*Fitted Lock Unit*Completion

- Ensure UNIT is level and tighten all fixings.

Testing (With door Open)

- Close strike lever on Unit, insert key to release
  - CAREFULLY close door onto Strike plate, to ensure lever will engage, if adjustment of the Strike plate is required, slightly loosen Screws and adjust as necessary.
  - Close strike lever on Unit, test Handle to release.
  - Close door, Use key to release lock, and open door by vehicle handle.
  - Re-fit door panels etc
- Cut an access in ply-lining for the emergency escape if necessary

**GMC SAVANA**

**SWING-OUT-SIDE DOOR**



**Note:** This Product is currently not available/recommended for the sliding side door variant.

**ENSURE THAT THE VEHICLE E.O. DOOR LATCH IS FUNCTIONING CORRECTLY. READ THE SUPPLIED INSTALLATION INSTRUCTIONS FULLY BEFORE STARTING ANY FITTING OF THIS LOCK**

Block Shaft Srl Unipersonale accepts no responsibility for damage or mistake

- 1- Remove any ply-lining (if fitted), from both lower side doors
- 2- Remove both lower panels using a suitable trim clip tool.
- 3- Clean area where lock will be fitted.
- 4- Stick adhesive drilling template to door in line with measurements market below.

**Lock fitting**

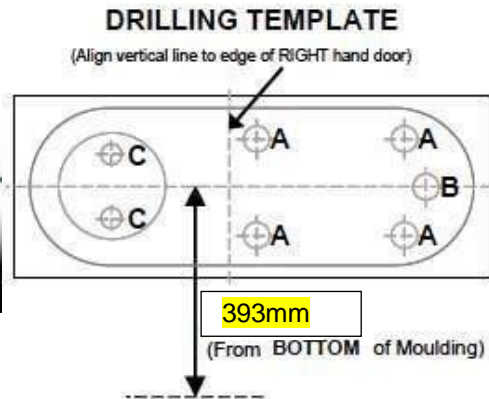
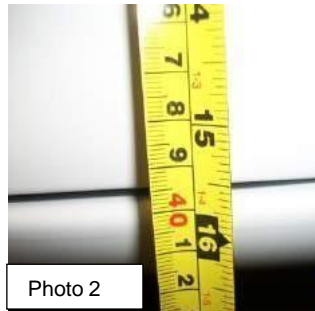

**FITTING INSTRUCTIONS**

**SIDE DOOR**

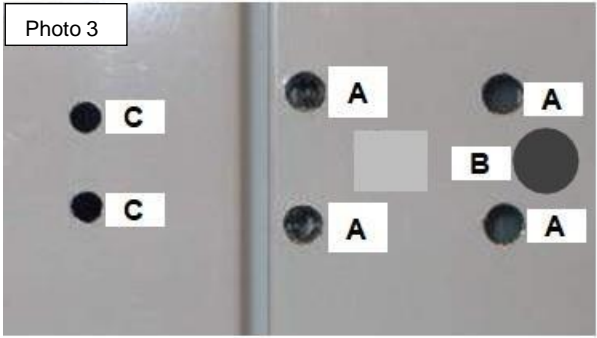

- Drill 4 x holes (A) to a maximum size of 9mm.
- Drill 1 x hole (B) to a maximum size of 10mm.
- Drill 2 x holes (C) to a maximum size of 9mm.  
**Note: it will also be necessary to drill through the edge of an inner brace, when drilling holes (C).**

(Note: All holes should be de-burred, where possible).  
 • Apply the anti-corrosion substance supplied, or paint holes.

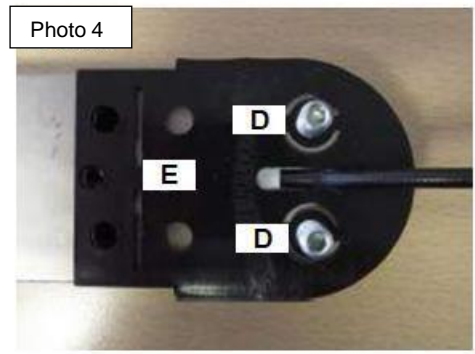

**Assemble Unit prior to fitting to door**

- Fit 2 x M8 Studs, (D) (fit with socket heads facing inwards). (Use of a thread locking compound is recommended).
- Fit Plastic Lock Shroud (E) over Escape Cable and Studs.

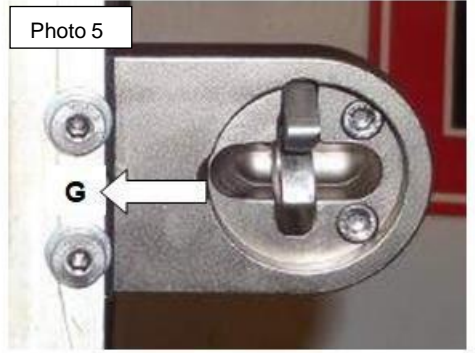

**Fitting Gatelock to door**

Fit 2 x M8 Studs with plusnuts (D) (fit with socket heads facing inwards). (Use of a thread locking compound is recommended). Fit Plastic Lock Shroud (E) over Escape Cable and Studs

Whilst every effort has been made to ensure the accuracy of details and information provided within the drawings and installation guides supplied by Legend Fleet. The Company gives no warranty in relation to the drawings and installation guides contained in the Goods and the Company accepts no liability for any inaccuracies or vehicle variations in the drawings. The information provided is supplied as a general guide only. It is the sole responsibility of the installation company and/or their fitter to check suitability of product for vehicle and application, component parts of kit and accuracy of any supplied information before commencing installation.



**FITTING INSTRUCTIONS**

**SIDE DOOR**

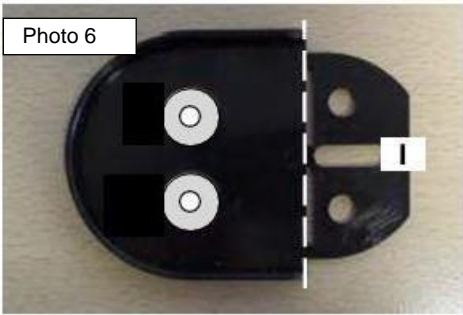

- Remove Plastic 'Unit Tilt' section (I).

Use cut off section (I) if Unit requires tilting over to improve locking, (this is more typical for barn doors).

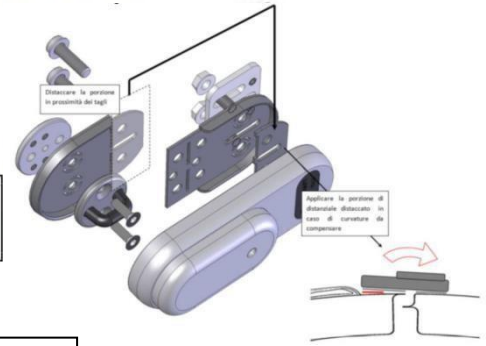

- Cut The edges where they will be installed the plusnuts (Photo 7)

Fitting Locking Strike

- Apply an anticorrosion substance or paint holes
- Fit M6 screws through strike plate with plusnuts
- Fit screws through plastic schroud, followed by external plate
- Fit screws through drilled holes



Internal Escape Cable Fitting

**Step 1:** Drill a 13mm hole on the door sheet metal (Or panel)

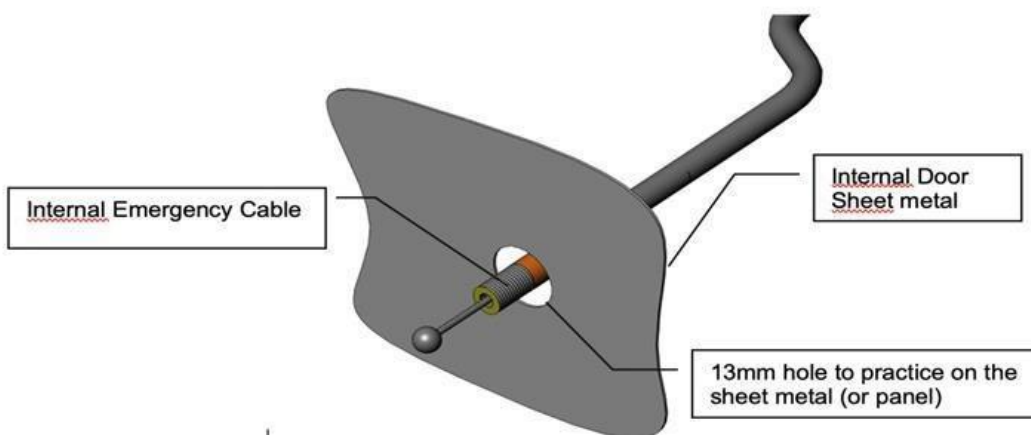

Whilst every effort has been made to ensure the accuracy of details and information provided within the drawings and installation guides supplied by Legend Fleet. The Company gives no warranty in relation to the drawings and installation guides contained in the Goods and the Company accepts no liability for any inaccuracies or vehicle variations in the drawings. The information provided is supplied as a general guide only. It is the sole responsibility of the installation company and or their fitter to check suitability of product for vehicle and application, component parts of kit and accuracy of any supplied information before commencing installation.

## FITTING INSTRUCTIONS

## SIDE DOOR

**Step 2:** Insert the red knob in its support, paying attention to align the holes as indicated below

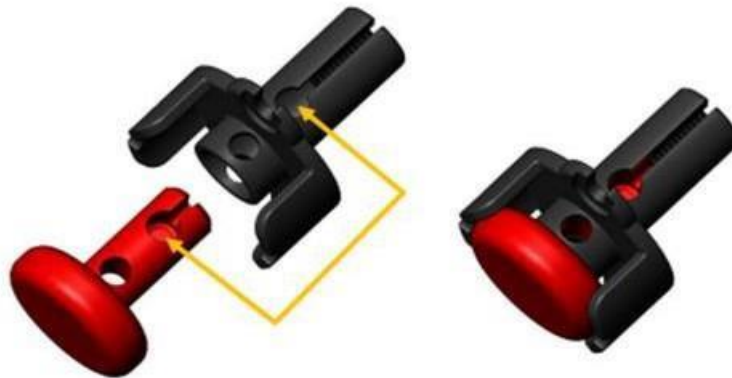

**Step 3:** Insert the terminal of the cable in its seat.

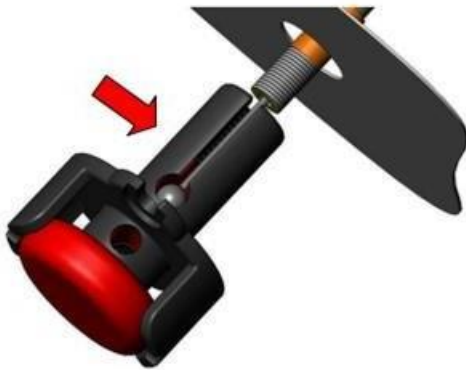

**Step 4:** Screw the plastic support until the ball end of the cable aligns with the top hole of the support



**Step 5:** Insert the support into the door sheet metal and close the padlock by rotating the harpoon (the red knob will return). Carry out some functional tests before fixing the plastic support. If necessary, screw or unscrew the support to adjust the stroke.

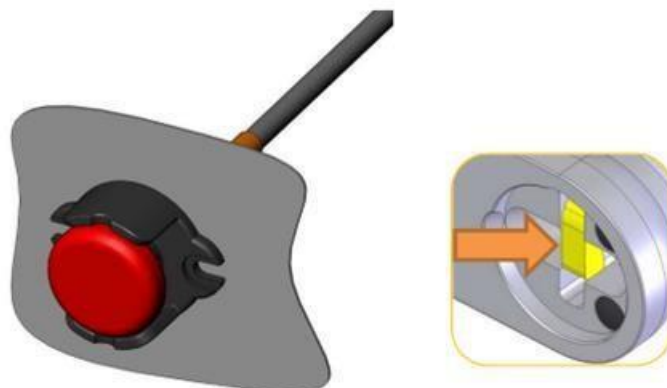

FITTING INSTRUCTIONS

SIDE DOOR

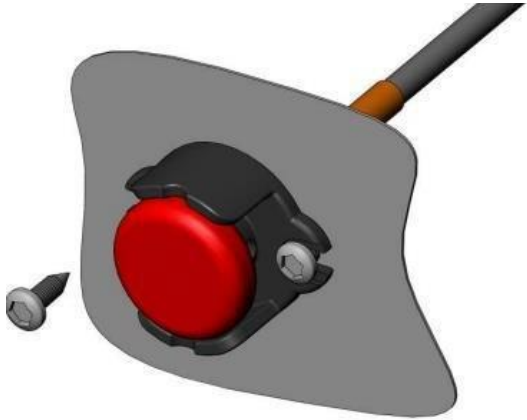

**Step 6:** Fix the support to the door sheet or to the panel using the screws provided. Check that the passing hole of the knob and that of the support are aligned in order to guarantee the passage of the safety seal

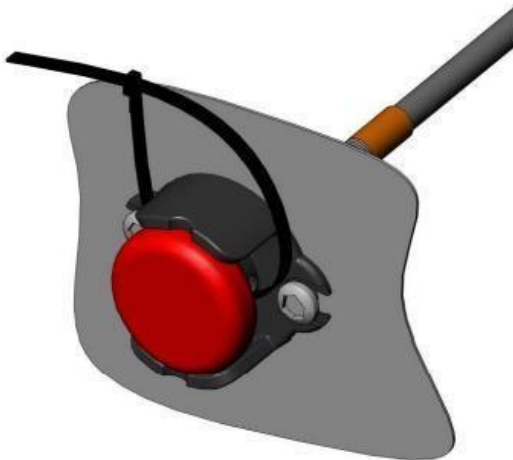

**Step 7:** Fix the support to the door sheet or to the panel using the screws provided.

**NOTE:** The emergency cable allows the use of a security seal. The use is **NOT MANDATORY** and it prevents the functioning of the emergency cable in case of any need.

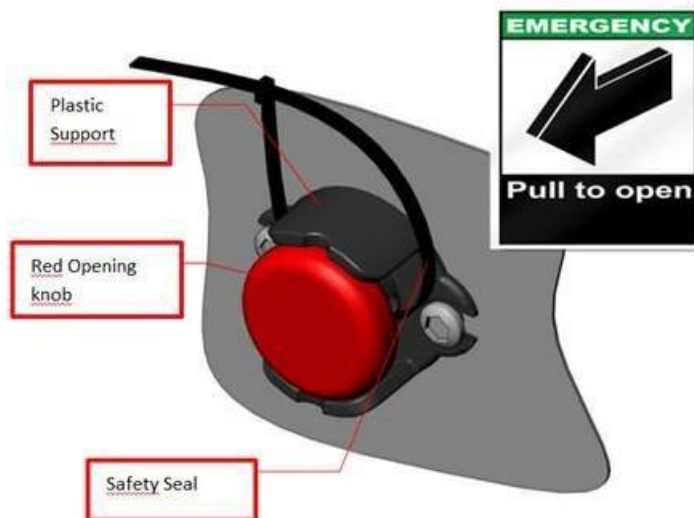

Whilst every effort has been made to ensure the accuracy of details and information provided within the drawings and installation guides supplied by Legend Fleet. The Company gives no warranty in relation to the drawings and installation guides contained in the Goods and the Company accepts no liability for any inaccuracies or vehicle variations in the drawings. The information provided is supplied as a general guide only. It is the sole responsibility of the installation company and or their fitter to check suitability of product for vehicle and application, component parts of kit and accuracy of any supplied information before commencing installation.

**FITTING INSTRUCTIONS****SIDE DOOR****Hold Emergency Escape Cable**

- Choose a position on the inside face of the door That has adequate access to fit the cable through The door (ensure cable will not be kinked or Interfere with latch etc)
- Centre punch, drill 8mm hole
- Push plastic support through drilled hole, fit screws to secure

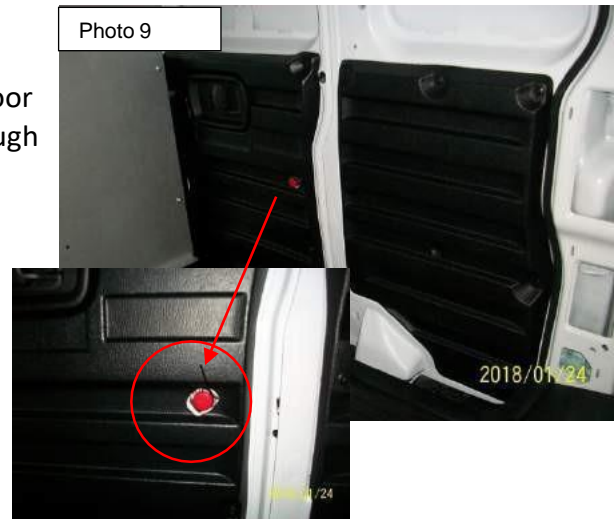
**Fitted lock Unit****Completion**

- Ensure UNIT is level and tighten all fixings.

**Testing (With door Open)**

- Close strike lever on Unit, insert key to release
- CAREFULLY close door onto Strike plate, to ensure lever will engage, if adjustment of the Strike plate is required, slightly loosen Screws and adjust as necessary.
- Close strike lever on Unit, test Handle to release.
- Close door, Use key to release lock, and open door by vehicle handle.
- Re-fit door panels etc
- Cut an access in ply-lining for the emergency escape if necessary.